

Contents

Company Profile	1
Custom Design and Production Services	1
Cylindrical Cells Ni-Cd Series	2
Selection Chart	2
Main Features	3
Typical performance and cell construction	4
Cylindrical Cells Ni-MH Series	5
Selection Chart	5
Main features	5
Typical performance	6
Sealed Lead Acid rechargeable batteries	7
Index and construction	7
Main features and typical performance	8
Button Cells	10
Lithium-manganese dioxide cell index	10
Alkaline button cell index	10
Ni-Cd and Ni-MH battery index and performance	11
EC-9V rechargeable battery index	12
Ni-Cd and Ni-MH 9V battery index and performance	12

Company Profile

EUROCAP is a professional supplier of Nickel Cadmium, Nickel-Metal Hydride rechargeable batteries, Sealed Lead Acid (SLA) batteries, button cells and packs.

The factory manufacturing our products was established in 1992. Since that time, there has been a policy of continuous improvement.

The variety of products has increased to meet the international demands of the customer.

The raw materials are imported from Germany and Japan and the production process is controlled to ISO 9002 standards.

The Quality Control Process is as follows

- 1 Raw Material Supplier Assessment
- 2 Inspection of Incoming Parts
- 3 Inspection of Raw Materials
- 4 In-process Quality Control
- 5 Final Inspection of Finished Products
- 6 Product Testing before Dispatch



Ni-Cd Battery Series

Type	Size	Nominal	Nominal	Charge Current In mA			Dimensions (mm)		Weight
		Voltage	Capacity	Standard	Quick	Rapid	Diameter	Diameter	Grams
		(V)	(mAh)	(15 hrs)	(5hrs)	(1.5hrs)	+/-0.5mm	+/-0.5mm	Grams
EC- 150AAA	2/3AAA	1.2	150	15	45	150	10	28	7
EC- 240AAA	AAA	1.2	240	24	72	240	10	44	10
EC- 280AAA	AAA	1.2	280	28	84	280	10	44	10
EC- 150N	N	1.2	150	15	45	150	11.6	28	8
EC- 200N	N	1.2	200	20	60	200	11.6	28	8
EC- 130AA	1/3AA	1.2	130	13	39	130	14	16.5	8
EC- 300AA	2/3AA	1.2	300	30	90	300	14	28	12
EC- 350AA	2/3AA	1.2	350	35	105	350	14	28	12
EC- 400AA	2/3AA	1.2	400	40	120	400	14	28	13
EC- 650AA	4/5AA	1.2	650	65	195	650	14	39.5	19
EC- 700AA	4/5AA	1.2	700	70	210	700	14	39.5	19
EC- 500AA	AA	1.2	500	50	150	500	14	49	21
EC- 600AA	AA	1.2	600	60	180	600	14	49	22
EC- 700AA	AA	1.2	700	70	210	700	14	49	23
EC- 800AA	AA	1.2	800	80	240	800	14	49	24
EC- 900AA	AA	1.2	900	90	270	900	14	49	25
EC- 1100AA	7/5AA	1.2	1100	110	330	1100	14	64.4	34
EC- 1200AA	7/5AA	1.2	1200	120	360	1200	14	64.4	36
EC- 210A	1/3A	1.2	210	21	63	210	16.5	16.8	9
EC- 500A	1/2A	1.2	500	50	150	500	16.5	27.5	16
EC- 600A	1/2A	1.2	600	60	180	600	16.5	27.5	17
EC- 1000A	4/5A	1.2	1000	100	300	1000	16.5	42.1	20
EC- 1100A	4/5A	1.2	1100	110	330	1100	16.5	42.1	24
EC- 1200A	A	1.2	1200	120	360	1200	16.5	48.5	30
EC- 1800A	7/5A	1.2	1800	180	540	1800	16.5	65.9	43
EC- 750SC	1/2SC	1.2	750	75	225	750	22.5	25	30
EC- 1100SC	4/5SC	1.2	1100	110	330	1100	22.5	32.5	36
EC- 1200SC	4/5SC	1.2	1200	120	360	1200	22.5	32.5	38
EC- 1300SC	SC	1.2	1300	130	390	1300	22.5	42.5	44
EC- 1500SC	SC*	1.2	1500	150	450	1500	22.5	42.5	46
EC- 1700SC	SC	1.2	1700	170	510	1700	22.5	42.5	48
EC- 1800SC	SC	1.2	1800	180	540	1800	22.5	42.5	50
EC- 2100SC	5/4SC	1.2	2100	210	630	2100	22.5	49	53
EC- 1200C	C	1.2	1200	120	360	1200	25.5	49	50
EC- 2200C	C*	1.2	2200	220	660	2200	25.5	49	76
EC- 2500C	C	1.2	2500	250	750	2500	25.5	49	82
EC- 2200D	1/2D	1.2	2200	220	660	2200	32.5	35.5	56
EC- 1200D	D	1.2	1200	120	360	1200	32.5	60.5	68
EC- 1800D	D	1.2	1800	180	540	1800	32.5	60.5	75
EC- 4500D	D	1.2	4500	450	1350	4500	32.5	60.5	123
EC- 5000D	D*	1.2	5000	500	1500	5000	32.5	60.5	123
EC- 7000F	F	1.2	7000	700	2100	7000	32.5	89	220

Main Features Ni-Cd Batteries

- 1 **High Capacity:** Our top cells have between 10% to 20% more capacity than other Ni-Cd batteries of the same size.
- 2 **Long cycle life:** At usual operating conditions. 200-1000 cycles can be expected.
- 3 **High discharge rate:** 70% of the capacity available at 1.2V with 1C rate.
- 4 **Low internal resistance:** the cells internal resistance is comparably lower than other manufacturers as a result of using good quality raw materials.
- 5 **Resealable Safety vent:** A resealable safety vent is built in to relieve internal pressure in the event of possible abuse conditions.
- 6 **Outstanding reliability:** Coming from the use of the best available raw materials and high technology.

Typical Performance of Ni-Cd cylindrical cells

1 Charging

Standard charging :

0.1C rate charge 14 to 16 hrs

Fast charging:

0.3C-1C rate, we recommend using a charger with \pm V or temperature sensor control.

See Figure 1 for charging of Ni-Cd cylindrical cells at various charging rates

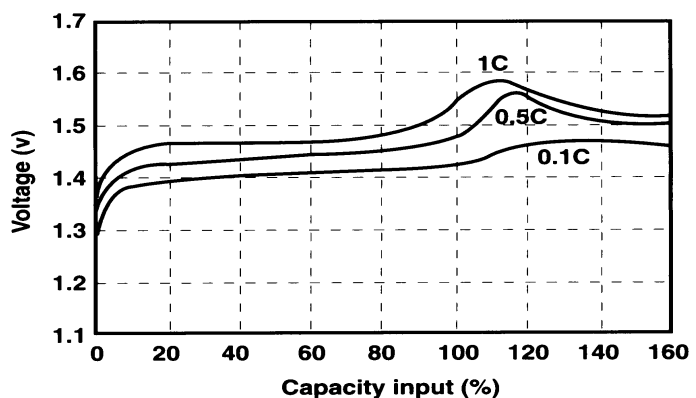

Fig. 1

2 Discharging

Nominal capacity is defined as the available capacity when discharged at 0.2 C for 5hrs at 20 °C to a cut off voltage of 1.0 V

EUROCAP batteries can be discharged from 1C to 3C. The discharge curves for Ni-Cd cells, at various discharge rates and temperatures are shown in Fig. 2.

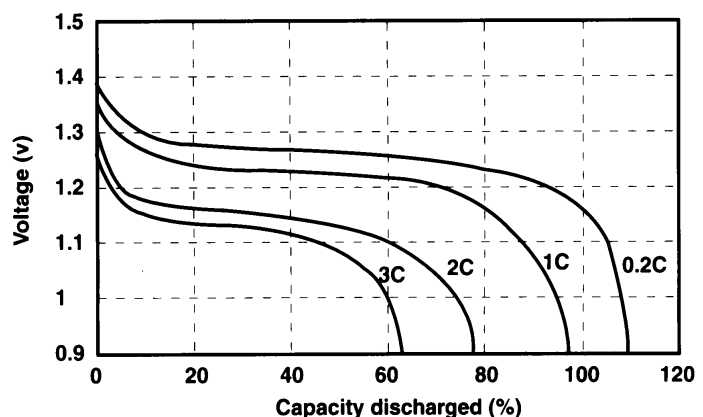
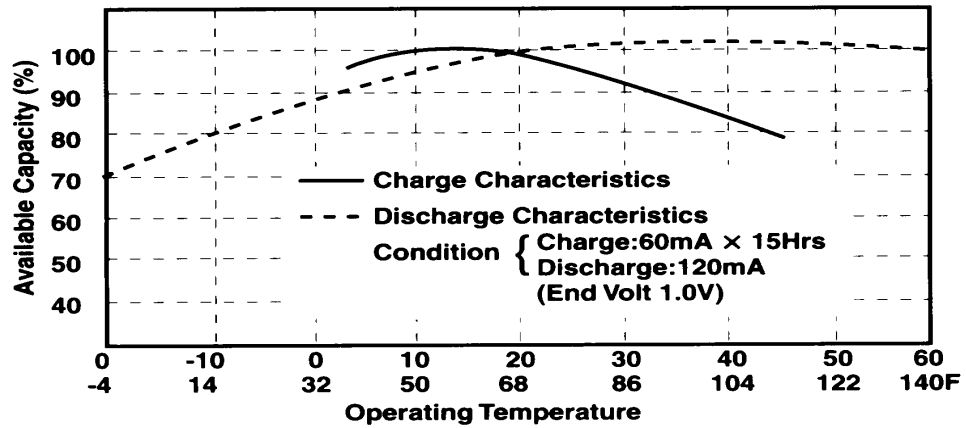

Fig. 2.

3 Charge and Discharge efficiency of Ni-Cd battery at various temperatures:



4 Cycle Life of Ni-Cd Cylindrical Battery

(Charge at 0.5 C, Discharge at 0.2 C / 20 °C)

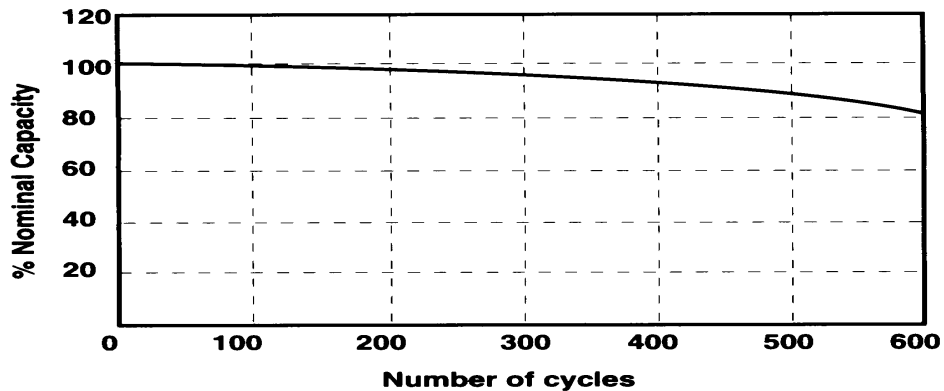

5 Battery construction

Construction of EUROCAP Rechargeable Ni-Cd Cylindrical Cells

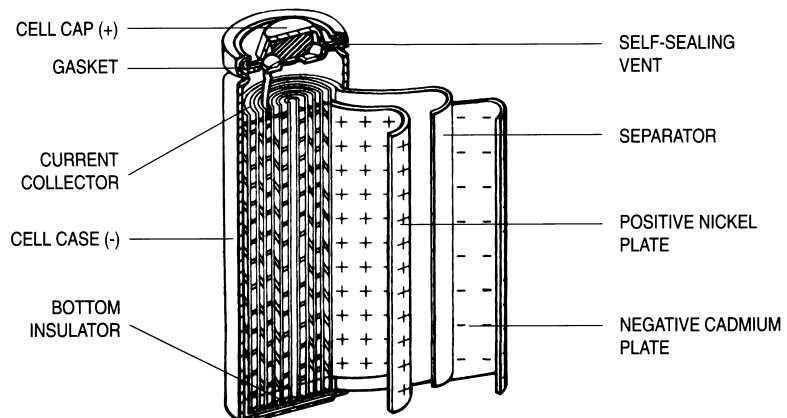

Ni-MH Battery Series

Type	Size	Nominal	Nominal	Charge Current In mA			Dimensions (mm)		Weight
		(V)	(mAh)	(15 hrs)	(5hrs)	(1.5hrs)	+/-0.5mm	+/-0.5mm	Grams
EC- 270AAA	2/3AAA	1.2	270	27	81	270	10	28	7
EC- 330N	N	1.2	330	33	99	330	11.6	28	8
EC- 500AAA	AAA	1.2	500	50	150	500	10	44	12
EC- 550AAA	AAA	1.2	550	55	165	550	10	44	13
EC- 200AA	1/3AA	1.2	200	20	60	200	14	16.5	9
EC- 500AA	2/3AA	1.2	500	50	150	500	14	28	15
EC- 550AA	2/3AA	1.2	550	55	165	550	14	28	16
EC- 600AA	2/3AA	1.2	600	60	180	600	14	28	16
EC- 1000AA	4/5AA	1.2	1000	100	300	1000	14	39.5	24
EC- 1100AA	4/5AA	1.2	1100	110	330	1100	14	39.5	25
EC- 600AA	AA	1.2	600	60	180	600	14	49	16
EC- 1100AA	AA	1.2	1100	110	330	1100	14	49	25
EC- 1200AA	AA	1.2	1200	120	360	1200	14	49	27
EC- 1800AA	7/5AA	1.2	1800	180	540	1800	14	64.4	44
EC- 1600A	4/5A	1.2	1600	160	480	1600	16.5	42.1	37
EC- 1800A	4/5A	1.2	1800	180	540	1800	16.5	42.1	40
EC- 1800A	A	1.2	1800	180	540	1800	16.5	49	40
EC- 2500A	7/5A	1.2	2500	250	750	2500	16.5	65.9	57
EC- 1200SC	1/2SC	1.2	1200	120	360	1200	22.5	25.5	26
EC- 2300SC	SC	1.2	2300	230	690	2300	22.5	42.5	52
EC- 3000SC	5/4SC	1.2	3000	300	900	3000	22.5	49	58
EC- 3200C	C	1.2	3200	320	960	3200	25.5	49	53
EC- 3300C	C	1.2	3300	330	990	3300	25.5	49	54
EC- 3000D	2/3D	1.2	3000	300	900	3000	32.5	35.5	62
EC- 7000D	D	1.2	7000	700	2100	7000	32.5	60	145
EC- 8500F	F	1.2	8500	850	2550	8500	32.5	89	250
EC- 10000F	F	1.2	10000	1000	3000	10000	32.5	89	258
EC- 12000F	F	1.2	12000	1200	3600	12000	32.5	90.5	270

Note :

We can design and manufacture other types of batteries according to customer requirements. The cell construction is the same as the Ni-Cd battery.

Main Features :

High Capacity : 30 - 50% more energy storage than Ni-Cd batteries of similar size.

No Memory Effect

Resealable Safety Vent : A resealable safety vent is built in, to relieve the internal pressure created by misuse.

High Discharge Voltage : Our cells have high voltages at higher rates of discharge than other cells.

Long Cycle Life : 280 - 1000 recharge cycles can be expected, depending on conditions of use.

Typical Performance of Ni-MH cylindrical cells.

Charging :

Standard charging rate :
0.1 C rate for 14 to 16 Hrs.
Fast Charging :
0.5 to 1 C charging, with the charger controlled with $-+ V$ or and dT/dt (1.0 °C/min).

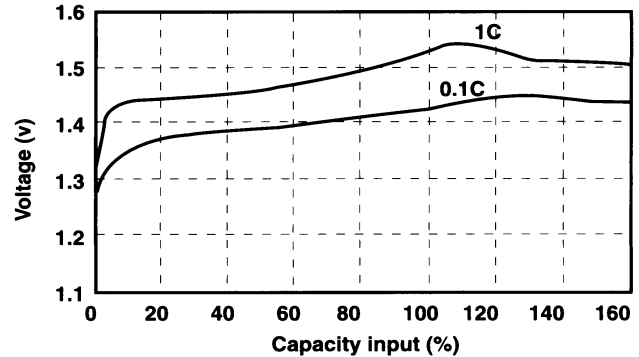

Discharging :

Discharge Curves of Ni - MH cylindrical cell at various discharge rates at room temperature.

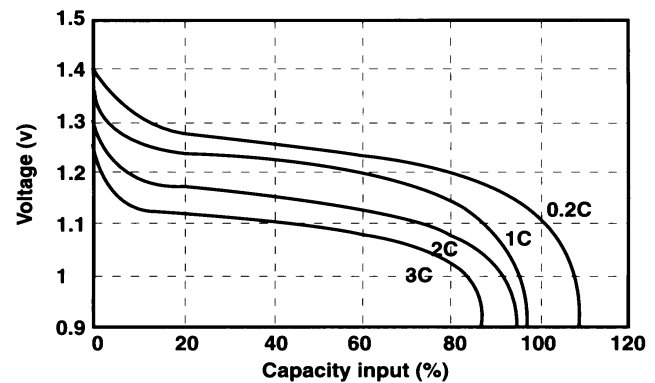

Cycle Life :

Cycle Life of Ni - MH cylindrical battery
Charge at 0.5 C and then discharge at 0.2 C at 20 °C

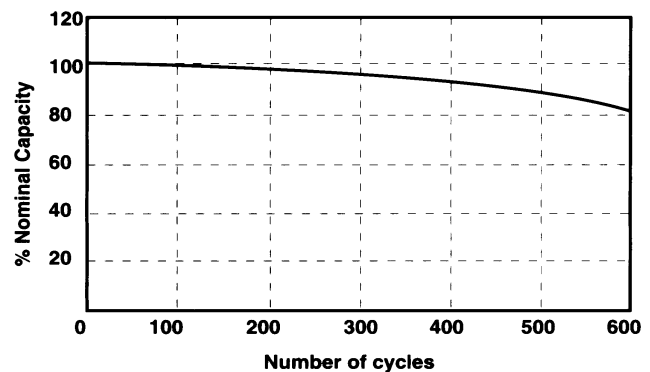

Charge and Discharge Efficiency

Ni - MH battery at various temperatures.

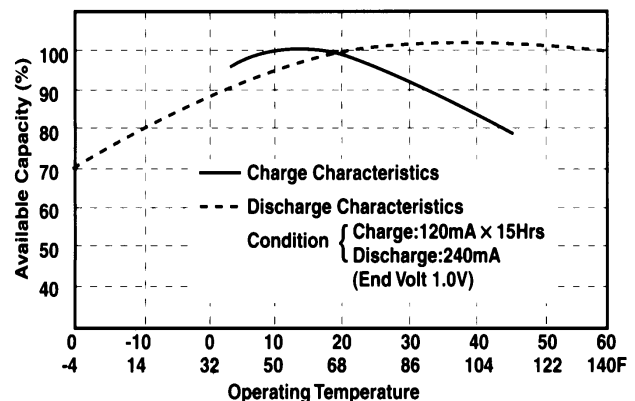

Sealed Lead -Acid Battery Series

Battery Index

Type	Nominal Voltage (V)	Capacity 20hr Rate Ah	Length		Width		Height		Total Height		Weight	
			mm	in	mm	in	mm	in	mm	in	Kgs	lbs
EC- 612	6	1.2	97	3.82	24	0.94	51.5	2.03	57.5	2.26	0.30	0.66
EC- 625	6	2.5	65.5	2.58	32.5	1.28	97	3.82	103	4.06	0.55	1.21
EC- 632	6	3.2	134	5.27	34.5	1.36	60.5	2.38	66.5	2.62	0.60	1.32
EC- 645	6	4.5	70	2.76	46.5	1.83	101	3.98	107	4.21	0.85	1.87
EC- 670	6	7.0	151	5.95	34	1.34	94	3.70	100	3.94	1.35	2.97
EC- 680	6	8.0	151	5.95	50	1.97	94	3.70	100	3.94	1.85	4.07
EC- 6100	6	10.0	151	5.95	50	1.97	94	3.70	100	3.94	2.00	4.40
EC- 6120	6	12.0	151	5.95	50	1.97	94	3.70	100	3.94	2.20	4.84
EC- 1212	12	1.2	97	3.82	43	1.69	52	2.04	58	2.28	0.60	1.32
EC- 1219	12	1.9	177.5	7.00	34.5	1.36	60.5	2.38	66.5	2.62	0.90	1.98
EC- 1223	12	2.3	177.5	7.00	34.5	1.36	60.5	2.38	66.5	2.62	1.00	2.20
EC- 1232	12	3.2	134	5.27	67	2.64	61	2.40	67	2.64	1.20	2.64
EC- 1245	12	4.5	90	3.54	70	2.76	101	3.98	107	4.21	1.85	4.07
EC- 1265	12	6.5	151	5.95	65	2.56	95	3.74	101	3.97	2.60	5.72
EC- 1270	12	7.0	151	5.95	65	2.56	95	3.74	101	3.97	2.80	6.17
EC- 12100	12	10.0	151	5.95	98	3.86	95	3.74	101	3.97	3.80	8.37
EC- 12120	12	12.0	151	5.95	98	3.86	95	3.74	101	3.97	4.00	8.80
EC- 12170	12	17.0	180	7.08	75	2.95	167	6.57	167	6.57	6.30	13.87
EC- 12250	12	25.0	175	6.89	166	6.53	125	4.92	125	4.92	8.90	19.60
EC- 12380	12	38.0	197	7.75	165	6.50	169	6.65	169	6.65	14.00	30.80
EC- 12650	12	65.0	355	13.98	167	6.57	179	7.05	183	7.20	24.00	52.80

Construction

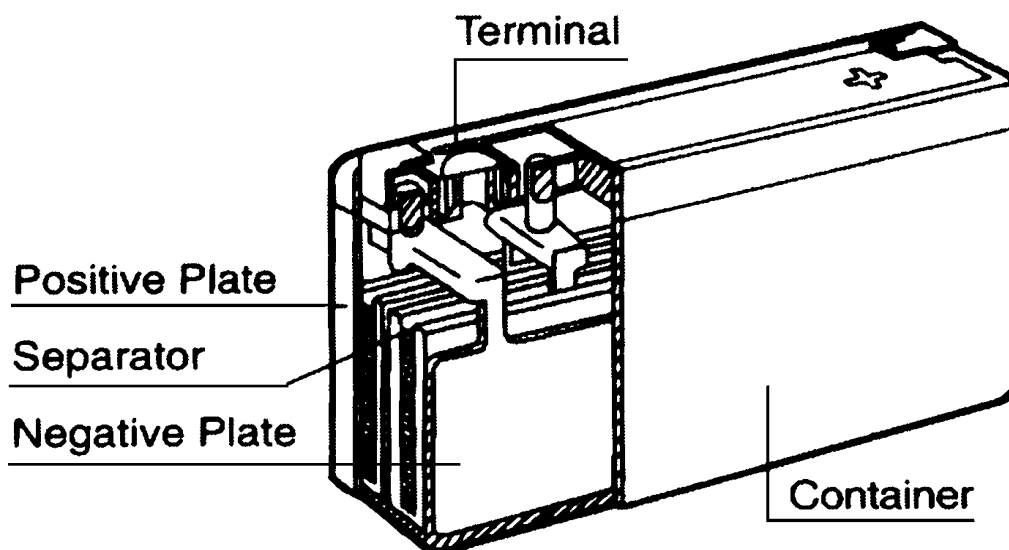

Major Features

Stable Features and High Reliability.

Withstands over charging and discharging, vibrational shock and capable of extended storage.

Maintenance free Operation.

Regular checks of Electrolyte properties is not required.

Heavy Duty Grids.

The heavy duty grids used in the EUROCAP SLA batteries give an extra margin of performance and service life, even with deep discharges.

Long Service Life.

With either float or cyclic charge / discharge cycles.

Low Self Discharge.

Due to the use of Lead Calcium grid alloy. EUROCAP SLA batteries can be stored for long periods without recharge.

Sealed Construction.

The unique construction and sealing technique guarantee that no electrolyte loss can occur.

Low Pressure Venting System.

The low pressure venting system operates between 1 psi to 6 psi.

Battery Charging

Constant Voltage Charging :

This is the recommended method of charging for SLA batteries. It is necessary to closely control the actual voltage to ensure it is within the advised limits.

Float Service 2.27 to 2.3 V / Cell @25 °C

Cyclic Service 2.4 to 2.45 V / Cell @25 °C

It is suggested that the initial current be set within 0.2 C Amps.

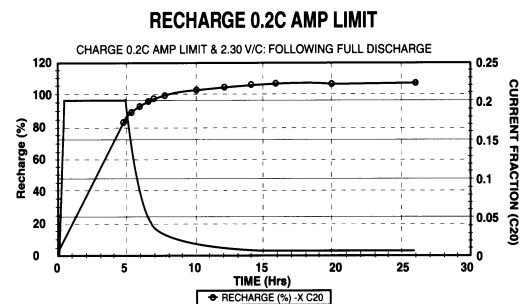

The graph indicates the time taken to fully charge a fully discharged battery.

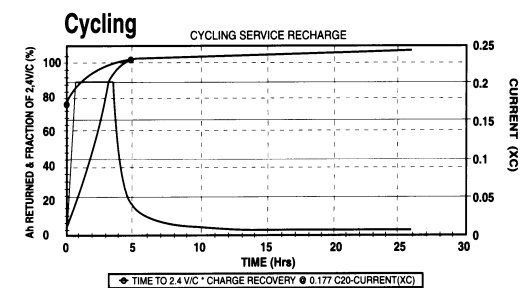

Battery Discharge

The discharge capacity of a lead acid battery varies and is dependent on the discharged current.

EUROCAP SLA batteries are specified at the 20 hour rate :

ie 20 hours to discharge to a end voltage of 1.75 V per cell at 25 °C.

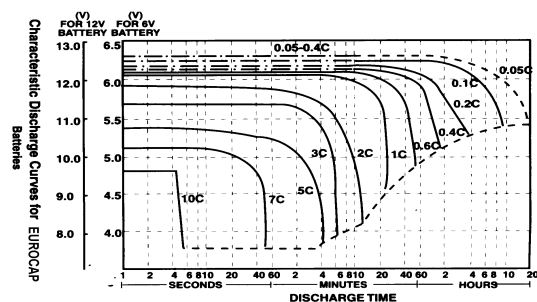

Battery Life

Battery Life depends on a number of key factors.

- 1) Operating temperature of the battery.
- 2) Method of charging.
- 3) Actual use of the product eg float charge or cyclic etc.

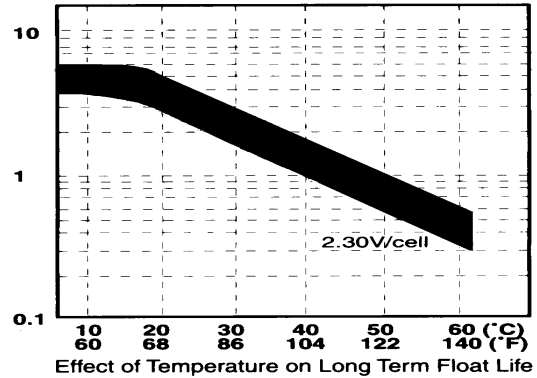

Float Service

The estimated life under float charge service is 3 to 5 years. The float service is effected by the factors listed above and the number and depth of discharges, the battery suffers during its life time.

Basically the more discharges suffered and the deeper the discharges, the shorter the battery life will be.

CYCLE SERVICE LIFE

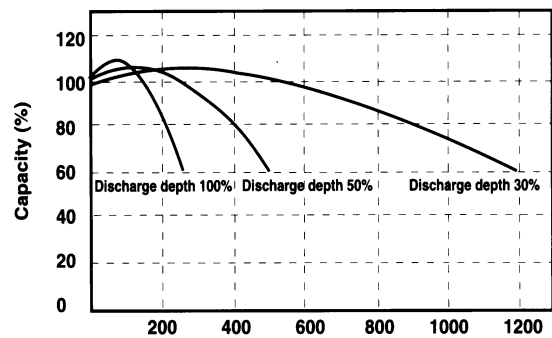

Cycle Service

Giving due consideration to the above factors, the actual life of a battery in cycle service is dependant on the depth of discharge of each cycle.

The greater the depth of discharge of each cycle, the lesser the number of cycles available from the battery.

RELATIVE BATTERY LIFE V'S TEMPERATURE FLOAT 2.25-2.30V/C

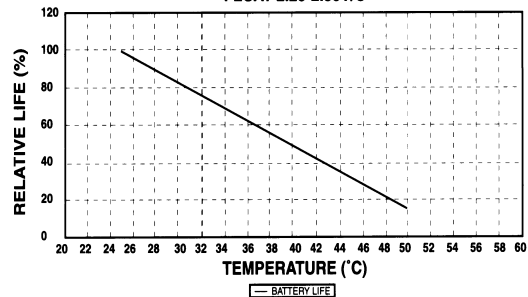

Self Discharge Characteristics.

SELF DISCHARGE OF EC BATTERIES

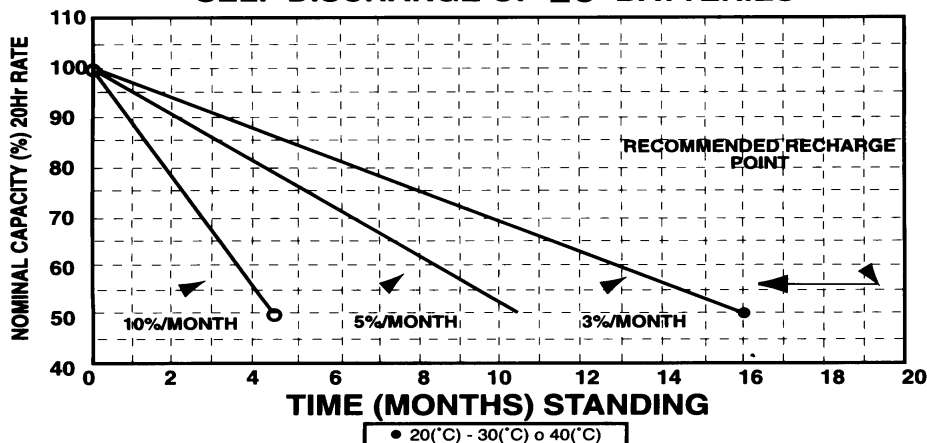

Button Cells

Lithium-Manganese Dioxide Button Cell (CR) Index

Type	Nominal Voltage (V)	Nominal Capacity mAH	Size		Weight g	Measurement Conditions			Continuous		Pulse Current Max mA
			Dia mm	Height mm		Temp ° C	Load K Ohms	Final Voltage	Discharge Time Hrs	Current max mA	
CR 2016	3.0	75	20	1.6	1.90	20	30	2.50	750	7.0	40
			-0.2	-0.1		-40			350		
CR 2025	3.0	150	20	2.5	2.50	20	15	2.50	750	8.0	45
			-0.2	-0.3		-40			350		
CR 2032	3.0	200	20	3.2	3.00	20	15	2.50	1000	7.0	40
			-0.2	-0.3		-40			510		
CR 1220	3.0	35	12.5	2.0	0.75	20	30	2.50	382	2.5	14
			-0.2	-0.2		-40			165		
CR 1616	3.0	40	16	1.6	1.10	20	30	2.50	450	4.0	20
			-0.2	-0.2		-40			300		
CR 1620	3.0	55	16	2.0	1.70	20	30	2.50	600	4.0	20
			-0.2	-0.2		-40			350		
CR 2430	3.0	270	24.5	3.0	4.20	20	30	2.50	2500	15.0	90
			-0.2	-0.2		-40			800		
CR 2450	3.0	550	24.5	5.0	6.20	20	15	2.50	2500	28.0	100
			-0.2	-0.2		-40			800		

Alkaline Button Cells

Model	Type	Nominal Voltage (V)	Nominal Capacity mA Hr	Dimensions mm		Weight g.
EC-3	LR41	1.5	26	7.9	3.6	0.59
EC-10	LR1130	1.5	64	11.6	3.1	1.11
EC-12	LR43	1.5	110	11.6	4.2	1.6
EC-13	LR44	1.5	128	11.6	5.4	1.95

Ni-Cd. and Ni-MH. Rechargeable Button Cells

Features

Long Service Life:	300 - 1000 Recharge Cycles
High Discharge Flat Voltage	1.2 V at 0.1C over 80% of the discharge cycle
Safety Features	All cells are subjected to 100% safety testing
High Reliability	By using the best available materials and technology

Ni-Cd Button Cell Index

Model	Nominal Voltage V	Nominal Capacity mAH	Dia. mm	Tol. mm	Height mm	Tol. mm	Charge Current mA	Charge Time Hrs	Trickle Current mA	Weight g.
280K	1.2	280	25.1	-0.2	8.6	-0.4	28	14	8	14
170K	1.2	170	25.1	-0.2	6.5	-0.4	17	14	5	10
100K	1.2	100	15.1	-0.2	7.6	-0.4	10	14	3	8
60K	1.2	60	15.1	-0.2	6.2	-0.4	6	14	2	4

Ni-MH Button Cell Index

Model	Nominal Voltage V	Nominal Capacity mAH	Dia. mm +0 /-0.2	Height mm +0 /-0.4	Charge Current mA	Charge Time Hrs	Trickle Current mA	Weight Grams
EC- 280H	1.2	330	25.1	8.6	33	14	9	14
EC- 170H	1.2	220	25.1	6.5	22	14	6	10
EC- 100H	1.2	110	15.1	7.6	11	14	3	8
EC- 60H	1.2	80	15.1	6.2	8	14	2	4
EC- 30H	1.2	40	11.6	5.5	4	14	1	2
EC- 12H	1.2	15	11.6	3.3	1.5	14	0.4	1.5

Typical performance of rechargeable button cells

Charging :

charging curve of Ni -MH button cell at 0.1C charging rate.

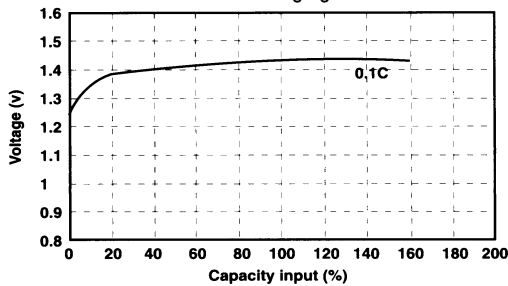

charging curve of Ni -Cd button cell at various charging rates.

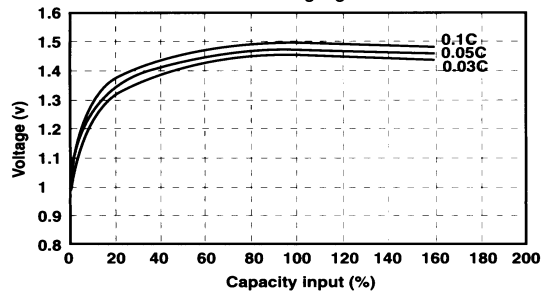

Discharging

Discharge curves of Ni -MH button cell at various discharge rates at room temperature.

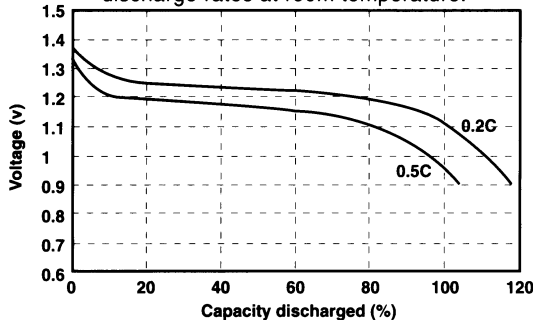

Discharge curves of Ni -Cd button cell at various discharge rates at room temperature.

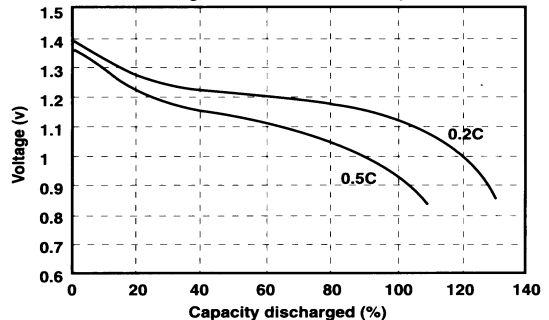

Cycle Life

cycle life curve of Ni -MH button cell charge 0.1C/discharge 0.2C.

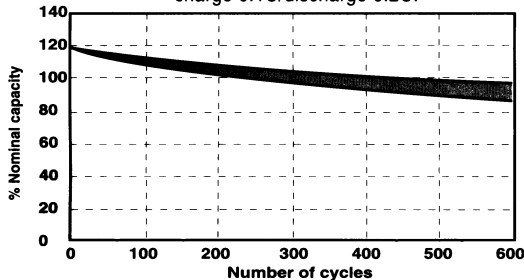

cycle life curve of Ni -Cd button cell charge 0.1C/discharge 0.2C.

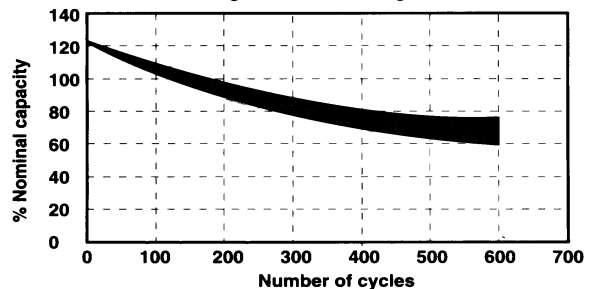

9 Volt Rechargeable Batteries

Dimensions

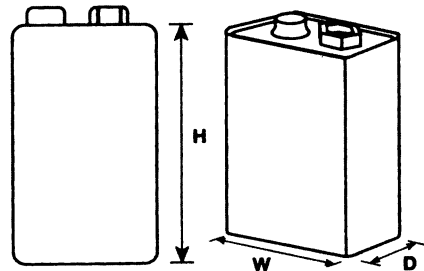

Dimensions of EUROCAP Rechargeable Ni-MH & Ni-Cd 9 V Batteries

Product Index

Type	Model	Nominal Capacity 5hr rate. mA Hr	Nominal Voltage	Dimensions			Wt gms	Stand Charge		Cut Off Voltage (V)
				D	W	H		mA	Hrs	
Ni-Cd	EC- 9V	100	8.4	17.5	26.5	48.5	42	10	14	7.0
Ni-Cd	EC- 9V	120	8.4	17.5	26.5	48.5	42	12	14	7.0
Ni-MH	EC- 9V	100	8.4	17.5	26.5	48.5	42	10	14	7.0
Ni-MH	EC- 9V	130	8.4	17.5	26.5	48.5	42	13	14	7.0
Ni-MH	EC- 9V	150	8.4	17.5	26.5	48.5	42	15	14	7.0

Charging

Charging curves of Ni-MH EC-9V cell

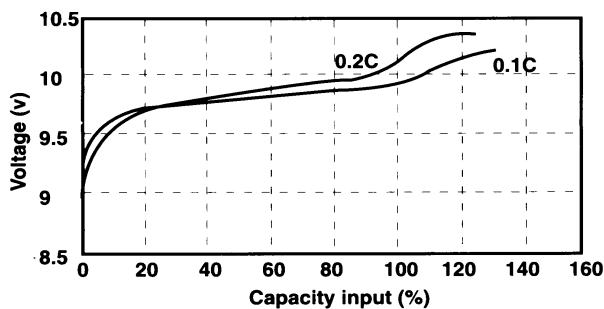

Charging curves of Ni-Cd EC-9V cell

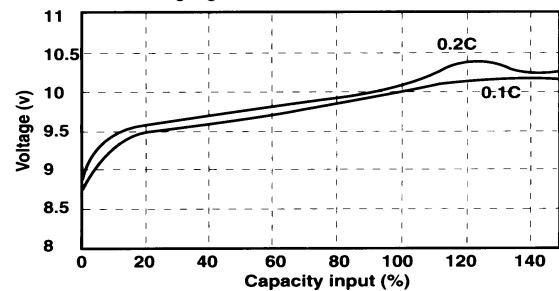

Discharging

Discharging curves of Ni-MH EC-9V cell

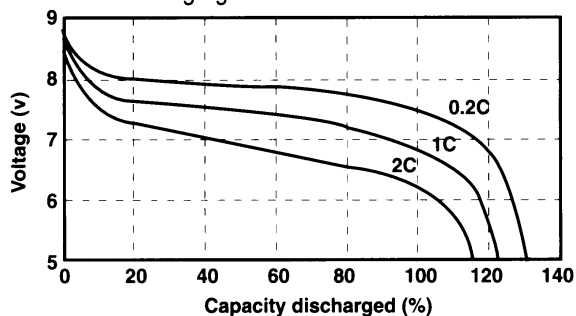

Discharging curves of Ni-Cd EC-9V cell

